

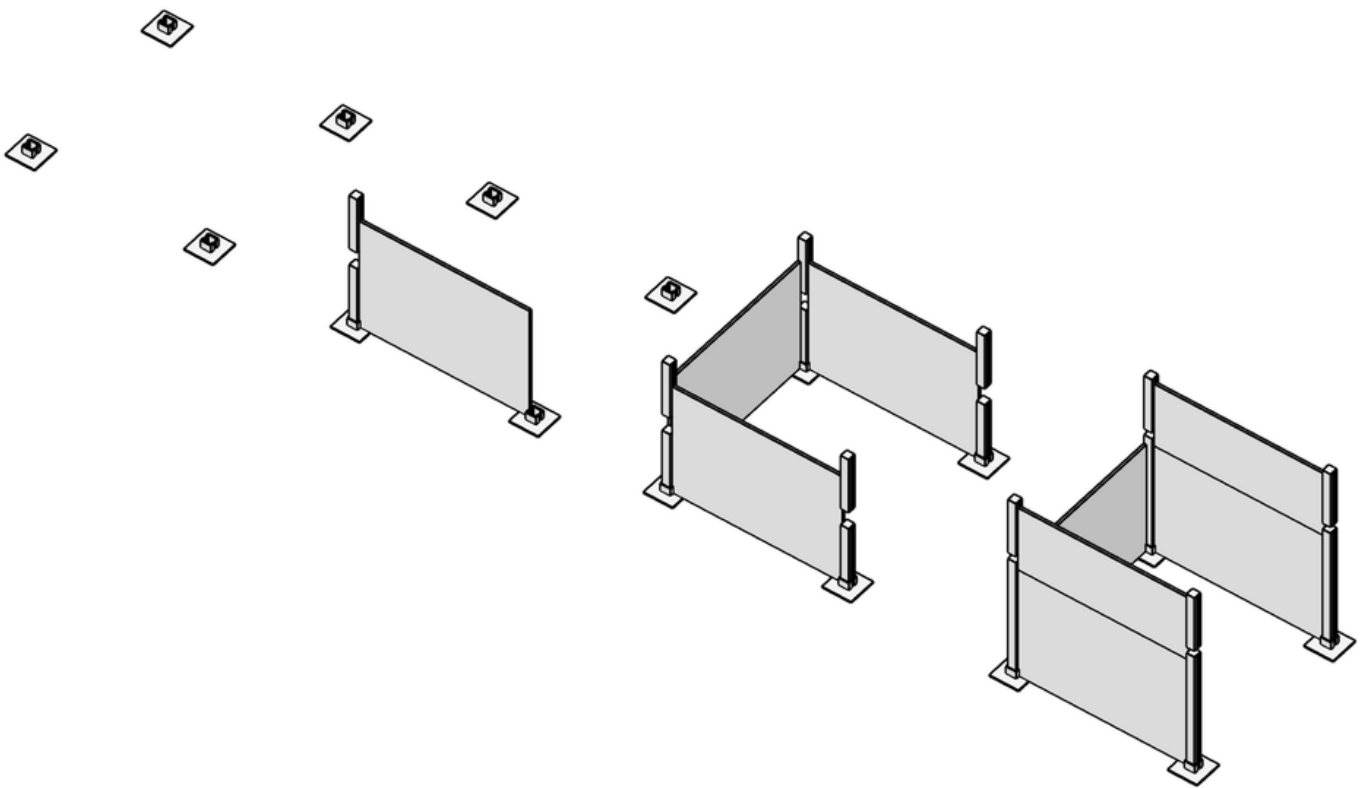

PORTABLE PARTITIONS

— AUSTRALIA —



SCAN FOR VIDEO



**Modular Office Cubicle
System Assembly Guide**

Step by step



Step 1

Arrange the feet into position

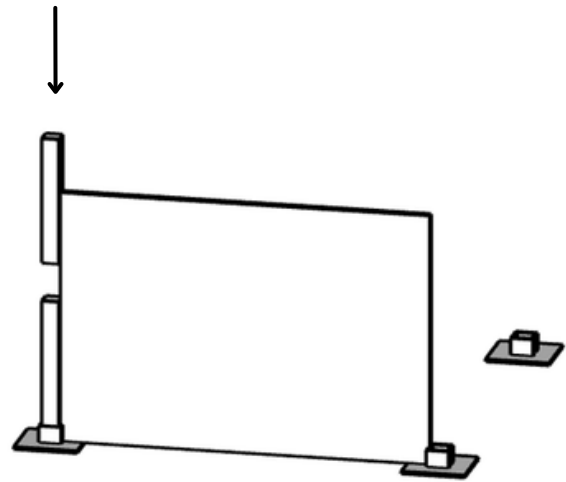

Step 2

Place the panel between the feet, and slide the posts through the panel and into the feet.

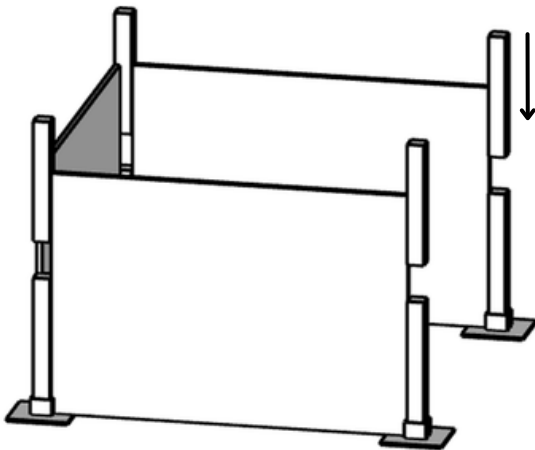

Step 3

Repeat for each additional panel

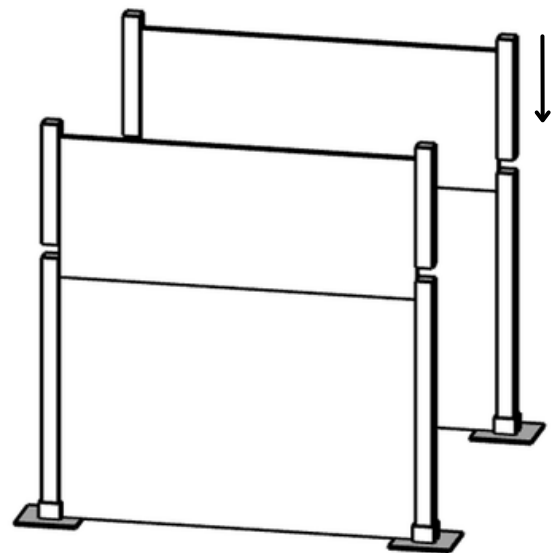

Step 4

If you have upper panels or windows slide them through the posts into position and then finish putting the upper posts

Components for some configurations

1.83 x 1.83m Panels

1.83m height Post and Foot



+

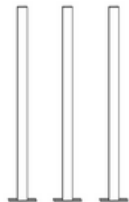

=

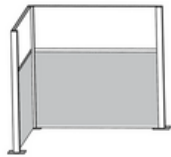

+

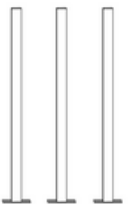

=

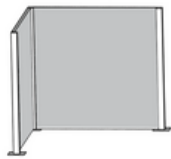

+

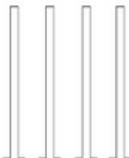

=

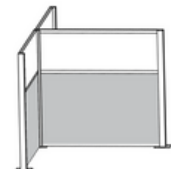

+

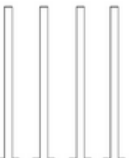

=

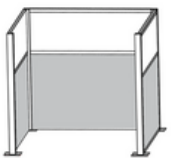

+

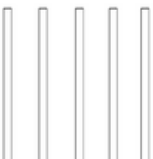

=

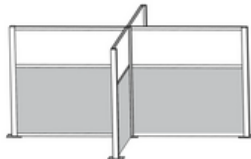

+



=

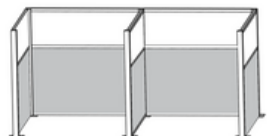

+

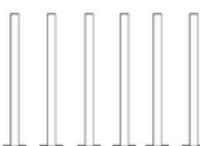

=

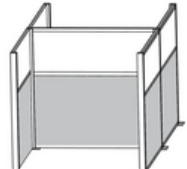

Panel dimension options

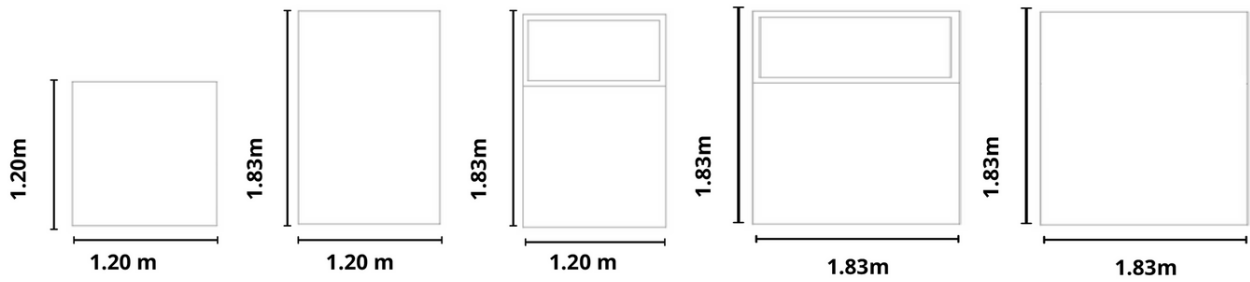

Popular configurations

L Shape

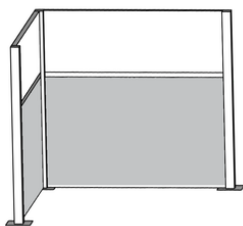

T Shape

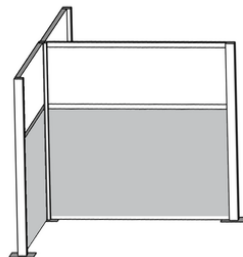

+ Shape

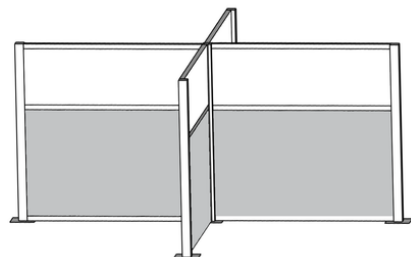

U Shape

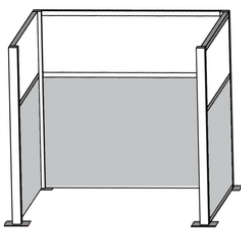

W Shape

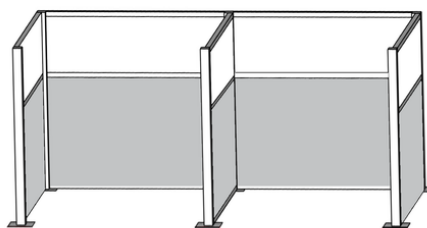

H Shape

